

Loch Sounder Interface

Product reference : 90-60-450



INSTALLATION GUIDE

Zi de Kerandré – Rue Gutemberg – 56700 – HENNEBONT – FRANCE

www.nke-marine-electronics.com

nke

MARINE ELECTRONICS



+33 297 365 685

TABLE OF CONTENTS

1	PRESENTATION	3
2	TECHNICAL SPECIFICATIONS.....	4
3	DIAGNOSTIC FOR 1ST LEVEL TROUBLESHOOTING.....	4
4	INSTALLATION	5
4.1	LIST OF ACCESSORIES.....	5
4.2	INSTALLATION PRECAUTIONS.....	5
4.3	INSTALLATION OF THE LOCH SOUNDER INTERFACE HOUSING	5
4.4	CONNECTION TO THE <i>TOPLINE</i> BUS.....	6
4.5	CONNECTION OF THE SENSORS.....	6

1 PRESENTATION

The **loch sounder interface** allows the connection of the speedometer log sensor and the depth-finder sensor to the **TOPLINE Bus** of your installation. This measurement instrument provides on the one hand the information on speed and distance covered by the ship, and on the other, the depth, the water temperature and the voltage of the power supply bus.

Depending on your performance requirements, you can use two types of log sensor :

- The speedometer log sensor with paddlewheel.
- The electromagnetic speedometer log sensor.

Architecture of the installation

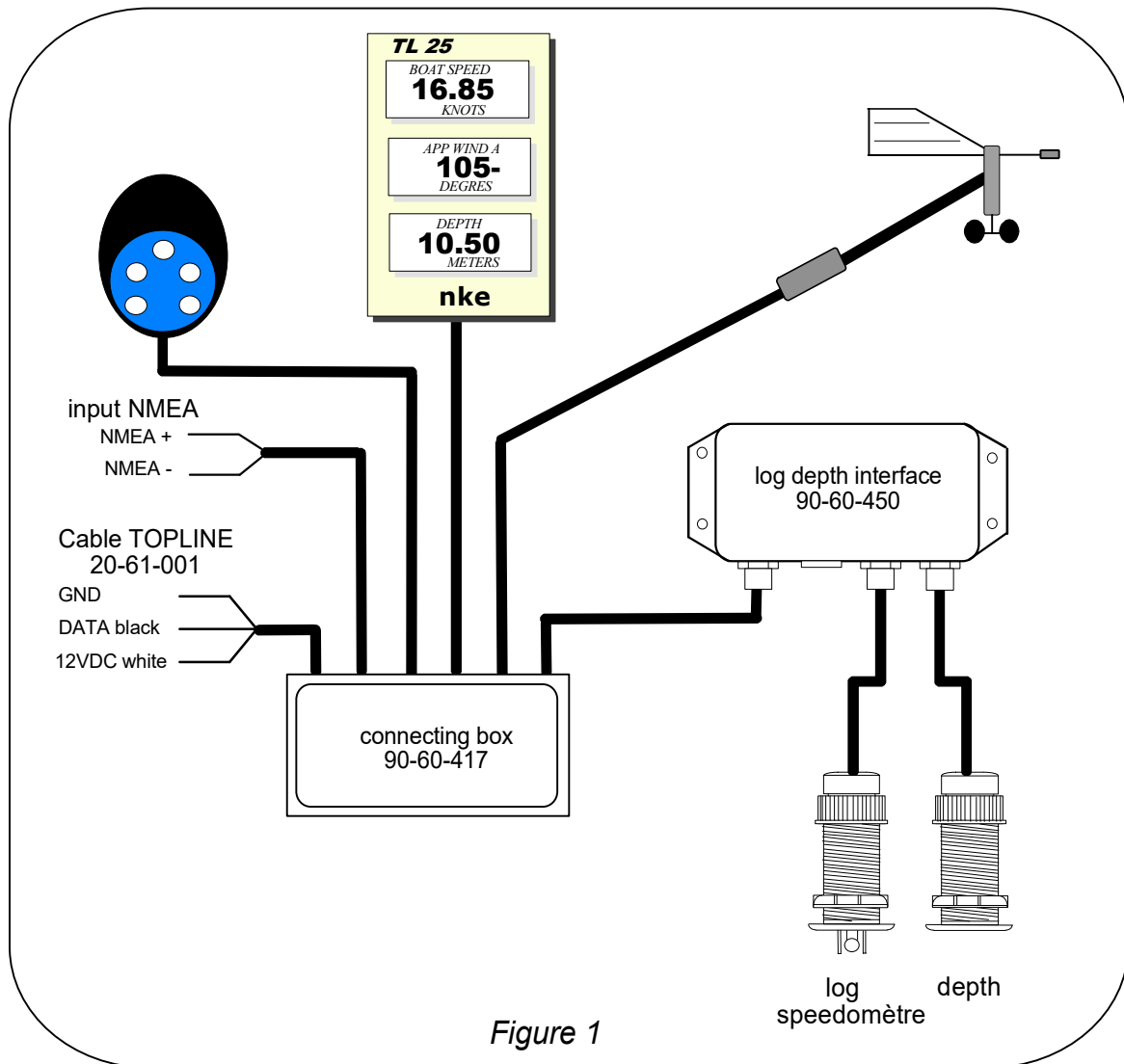

Figure 1

IMPORTANT

- Read this user guide entirely before starting the installation.
- Any electrical connection on the **TOPLINE bus** must be carried out with the terminal box 90-60-121. Only use **TOPLINE bus** cable of the type 20-61-001.
- Any intervention on the **TOPLINE bus** must be carried out with the installation power switched off.
- For channel settings, please refer to your **TOPLINE** display guide.

2 TECHNICAL SPECIFICATIONS

- Power supply : 10 to 16VDC
- Consumption : 60mA
- Tightness :IP54
- Weight : 160 g
- Operating temperature : -10°C to +50°C
- Storage temperature : -20°C to +60°C

3 DIAGNOSTIC FOR 1ST LEVEL TROUBLESHOOTING.

This chapter can help you rapidly resolve minor problems which do not require the intervention of a specialist. Before contacting technical support, please check the troubleshooting table below.

Problem	Possible causes and solutions
The Topline installation does not detect the Loch sounder interface	The bus cable is not or is badly connected to the terminal box : check the plugging and the connection inside the terminal box. Check the state of the cables : they must not show any sign of wear or cut.
The surface speed displayed is 0.00 , no matter what the speed of the ship is.	Check that the vaned rotor is not clogged (algae, seashells). Check that the calibration coefficient is not set to 0.00 : see chapter 3.
The surface speed displayed is 0.00 and the water temperature channel displays « Pan ».	It may be that the log sensor is badly connected or broken. Check the state of the cable and the connection to the box.
The depth-finder displays depth but the display flickers intermittently.	Your depth-finder is struggling to detect the seabed ; clean the surface of the depth-finder sensor.
The depth-finder continuously displays a constant depth : example 2.10	It may be that the depth-finder is detecting the keel and not the seabed. Please refer to the installation guide of the depth-finder sensor.
Your display indicates battery fault .	Check the voltage of your battery with a voltmeter : the operating voltage must be above 10VDC. Check that the battery maintains the load.

If you do not manage to solve the problem, please contact your distributor.

4 INSTALLATION

4.1 List of accessories

- 15 meter bus cable fitted with a connector : 90-60-460
- TOPLINE Terminal box : 90-60-121
- Cable adapter for old version of depth-finder sensor 90-60-453.
- Cable adapter for old version of vaned rotor log sensor : 90-60-454
- TOPLINE bus connector : 90-60-465.

4.2 Installation precautions

It is recommended to mount this housing towards the bow of the ship and at a certain height, in a location that is unlikely to get flooded.

4.3 Installation of the loch sounder interface housing

The housing of the **loch sounder interface** is splash-proof. It is fitted with three connector sockets for the connection of the depth-finder sensor, the log sensor and the TOPLINE bus cable. The housing will be mounted using four M4 screws (not included).

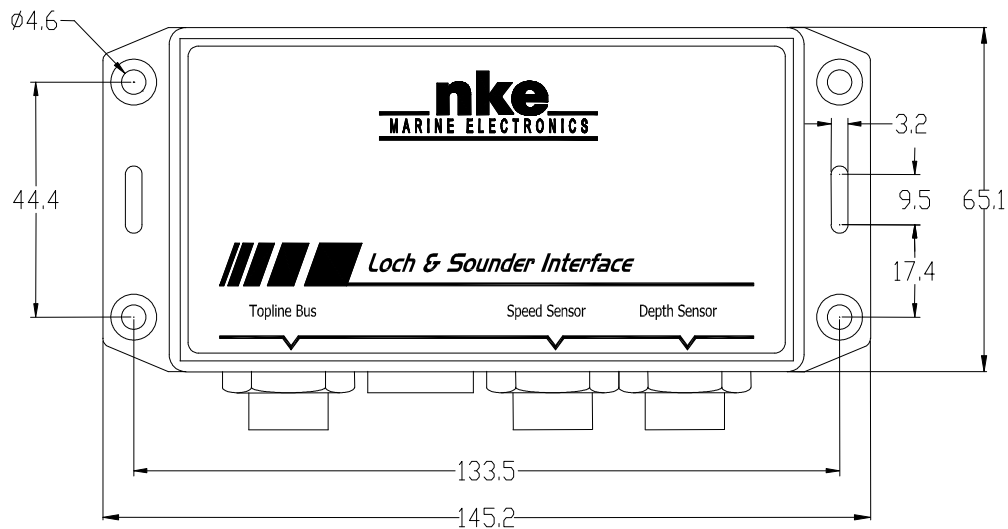

Figure 2

CAUTION :

- To guarantee the watertightness of the **loch sounder interface**, make sure the connectors are firmly screwed onto the connector sockets.
- The connection of the sensors must be performed with the installation power switched off.

4.4 Connection to the *Topline* bus

1. Make the bus cable run from the **loch sounder interface** to the **TOPLINE** terminal box of your installation.
2. Connect the bus cable inside the terminal box.

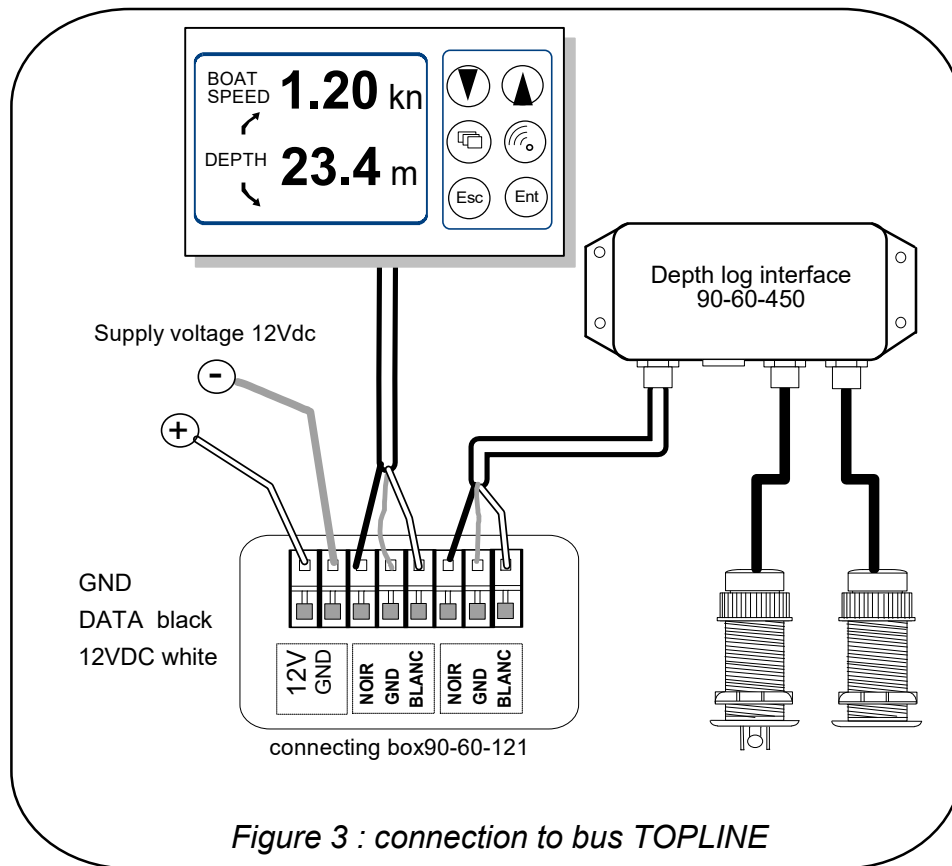

If you reduce the length of the bus cable 90-60-460, strip and galvanise the wires before connecting them inside the terminal box.

4.5 Connection of the sensors

The sensors are equipped with a 6 meter cable and a moulded waterproof connector. You will connect the speedometer log sensor, vanned rotor or electromagnetic, onto the connector socket marked **speed sensor** and the depth-finder sensor onto the **depth sensor** connector socket (see figure 2).

