

# Mast rotation sensor

Product # 90-60-084

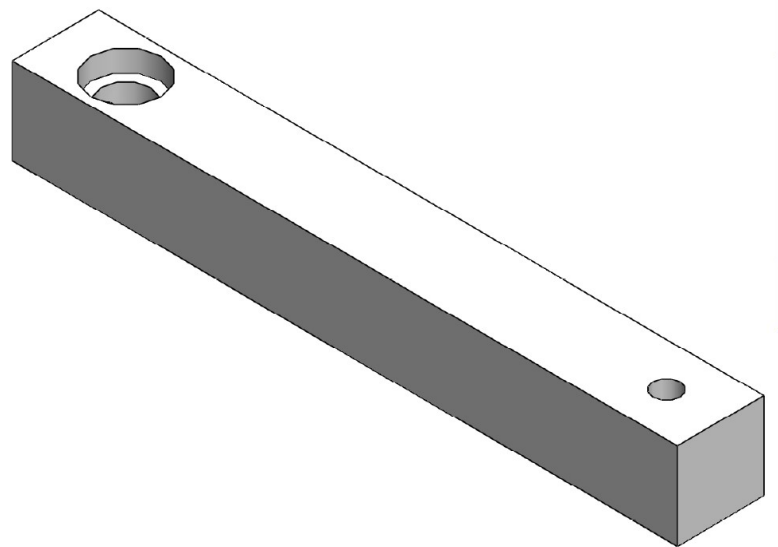
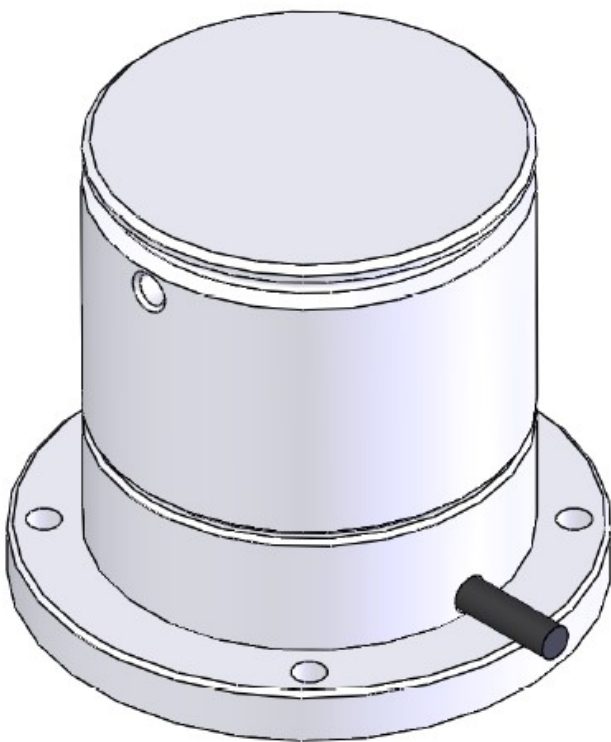

## USER MANUAL AND INSTALLATION GUIDE

Zi de Kerandré – Rue Gutemberg – 56700 – HENNEBONT – FRANCE

[www.nke-marine-electronics.com](http://www.nke-marine-electronics.com)

**nke**

**MARINE ELECTRONICS**



+33 297 365 685

## INDEX

<b>1</b>	<b>INTRODUCTION</b> .....	<b>3</b>
<b>2</b>	<b>THE DISPLAYED CHANNEL</b> .....	<b>4</b>
<b>3</b>	<b>CALIBRATING THE SENSOR</b> .....	<b>4</b>
3.2	ENTERING AN OFFSET VALUE .....	4
3.2.1	<i>Principle</i> .....	4
3.2.2	<i>Entering the OFFSET value (default value is 0):</i> .....	4
3.3	DETERMINE THE CALIBRATION VALUE (REDUCTION RATIO).....	4
<b>4</b>	<b>SPECIFICATION</b> .....	<b>5</b>
<b>5</b>	<b>TROUBLESHOOTING – FIRST LEVEL</b> .....	<b>6</b>
<b>6</b>	<b>PACKING LIST</b> .....	<b>6</b>
<b>7</b>	<b>INSTALLATION</b> .....	<b>6</b>
7.1	MAST ROTATION SENSOR MOUNTED WITH SHEAVES.....	7
7.1.1	<i>Mounting position</i> .....	7
7.1.2	<i>Mounting the sensor</i> .....	7
7.2	MAST ROTATION SENSOR MOUNTED WITH THE RUDDER ARM.....	8
7.2.1	<i>Mounting position</i> .....	8
7.2.2	<i>Mounting the sensor</i> .....	8
<b>8</b>	<b>CONNECTING TO THE <i>TOPLINE BUS</i></b> .....	<b>9</b>

## 1 INTRODUCTION

---

The « mast rotation sensor » from NKE is designed to measure the angle of a rotating mast in relation to the boat's centerline. The instrument system uses this information as a correction value to keep wind angle readings from the masthead unit relative to the center line. It is linked to the **NKE TOPLINE bus** thru an interface box (supplied).

The sensor is supplied with a 3 meters (9.84 feet) of **TOPLINE bus** cable and a **TOPLINE** interface box.



### **WARNING**

- Read this installation guide carefully before you start installation
- Any connection to the **TOPLINE bus** must be performed thru the specific interface box # 90-60-121 and only with the **TOPLINE bus** cable # 20-61-001.
- Make sure your system is powered off before doing any installation or service work starts.
- Channels settings are fully described in the **TOPLINE** displays manuals. Have these ready to refer to.

## 2 THE DISPLAYED CHANNEL

---

Once the « mast rotation sensor » is connected to the **TOPLINE bus** on your system, a new channel is created as described in the following table:

Channel	Display	Unit
ANG_INCI	MAST ANGLE ➡ 2°	Degrees

The **ROTATING MAST ANGLE** (ANG\_INCI) channel is available from any display in the **TOPLINE** range.

## 3 CALIBRATING THE SENSOR

---

To achieve optimum performance from the system an offset value and a calibration value needs to be determined and, if necessary, applied. The method used to calculate these values will be determined by the installation configuration (see Section 6)., When the values have been determined they must be entered in the system. via one of the displays. The data entry process is described below and more information can be found in the display.

### 3.2 ENTERING AN OFFSET VALUE

#### 3.2.1 Principle

Once the mechanical installation is completed, you may have to apply a correction value so that the angle displayed is in line with the effective angle of mast rotation. This is the sensor **OFFSET**.

#### 3.2.2 Entering the **OFFSET** value (default value is 0):

The system allows you to enter an angle correction from -180° to +180°.

- Within the **ROTATING MAST ANGLE (ANG\_INCI)** channel, select the sub-channel “**calib offset**”.
- Enter the new **offset** value and lock it. This will be stored in the instrument memory and affect the **ROTATING MAST ANGLE (ANG\_INCI)** channel.

### 3.3 DETERMINE THE CALIBRATION VALUE (REDUCTION RATIO).

Due to variations from boat to boat calibration may be required. When the value has been determined it must be entered in the system. via one of the displays. The data entry process is described above and more information can be found in the display manual.

The « mast rotation sensor » can be mounted either with the sheave (see figure 2) or with the rudder arm supplied (see figure 3).

-When the sensor is mounted with the sheave, the calibration value must be calculated using from the diameter of the other sheave mounted at the base of the mast as follows:

**Calibration value = mast base sheave Ø (mm)**

**50.1**

-When the sensor is mounted with the rudder arm and link-rod: **Calibration value = 1.**

#### **4 SPECIFICATION**

---

##### General :

- Power supply: 10 to 16Vdc
- Consumption: 15mA
- Protection: sensor is IP67 and interface box is IP54 (to be mounted in a protected area)
- Weight: 450gr (sensor + sheave + interface box);  
550gr (sensor + rudder arm + interface box + link-rod)
- Operation temperature range: -10°C to +50°C (14°F to 122°F)
- Storage temperature range: -20°C à +60°C (68°F to 140°F)

##### Measured data :

- Measurement range: -170° to +170°
- Resolution : 0.1 °
- Linearity: 2%

## 5 TROUBLESHOOTING – FIRST LEVEL

Before calling the NKE Customers Technical Support, please read the following table. If you cannot solve a problem by yourself, please contact your local distributor.

Problem	Possible causes and solutions
The mast rotation sensor is not detected by the <b>Topline</b> system	The bus cable is not correctly connected. Check the connections and that the cable does not show any shaving nor damage.
The <b>Topline Angle Mat</b> channel reads the error message PANNE.	Power the sensor off for a few seconds and then on again. If the error remains, please contact Customer Technical Support.
The <b>Topline Angle de Vent Apparent</b> channel reads the error message PANNE.	The apparent wind angle information uses both the mast rotation sensor and the masthead unit. If either sensor or the connection to them are not functioning correctly or damaged, then Apparent Wind Angle can no longer be calculated. First check the mast rotation sensor and cables, then the mast head unit.

## 6 PACKING LIST

- One rotating mast sensor
- One rudder arm
- One link-rod
- One interface box

## 7 INSTALLATION

The mast rotation sensor comes with the sheave already in place. If you need to use the rudder arm and link-arm configuration for installation the sheave will need to be removed and replaced with the rudder arm as described below:

- Unscrew the sheave using a 2.5mm Hex key
- Remove the sheave by pulling it up
- Mount the rudder arm on the pin and lock it with the screw on the pin's flat side (as shown on the drawing)
- Tighten the screw using a 2.5mm Hex key

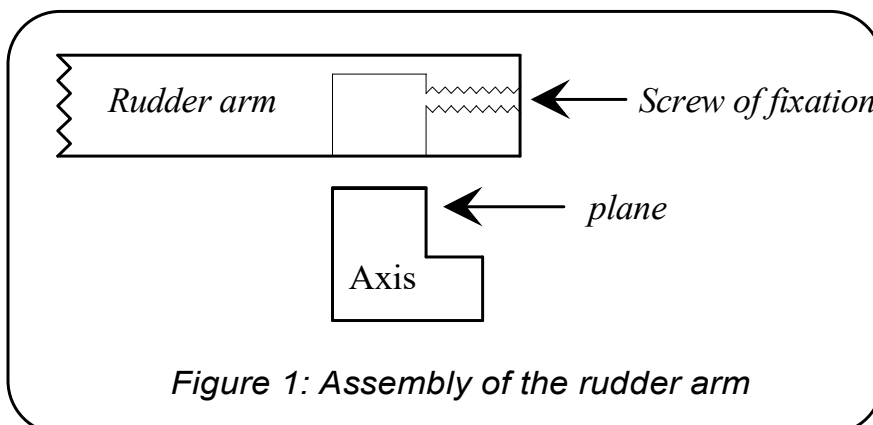
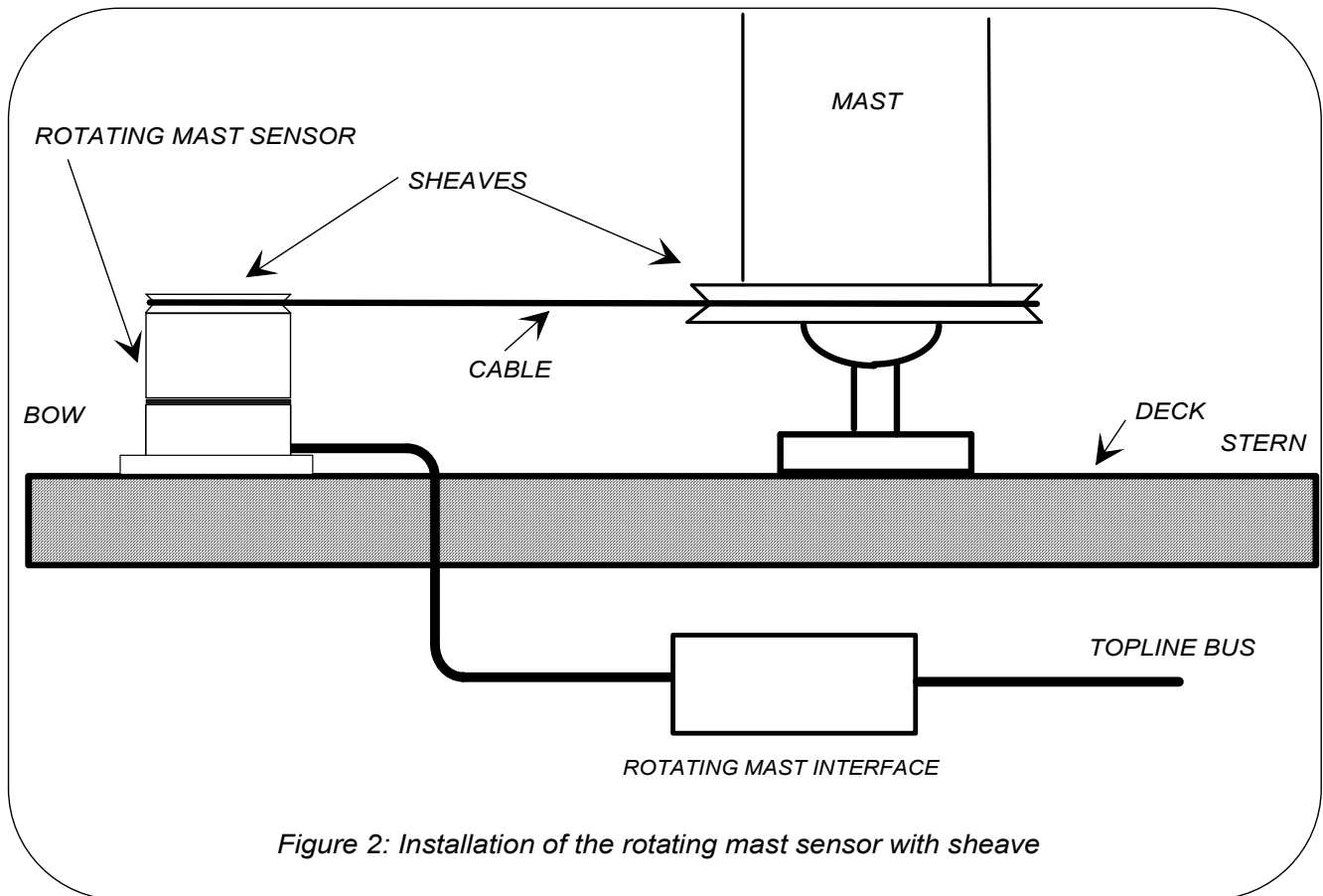

Figure 1: Assembly of the rudder arm

## 7.1 MAST ROTATION SENSOR MOUNTED WITH SHEAVES



### 7.1.1 Mounting position

- When positioning the mast rotation sensor, make sure **the cable is leading aft**. The sensor has a dead sector of  $\pm 10^\circ$  around the  $180^\circ$

### 7.1.2 Mounting the sensor



#### WARNING

The Rotating Mast Sensor with the sheave must not be positioned head to foot.

Before completing the installation, you must check that the mast can freely rotate and that nothing can interfere with or damage the sensor and its wire.

- The mast rotation sensor must be positioned on the deck as shown in Figure 2. Securely fasten, with four screws ( $\varnothing 4\text{mm}$ )
- Check the mast rotation angle before putting the wire in place. The mast rotation sensor will indicate "0" when the sheave's screw is positioned vertically aligned to the cable.
- Once the wire is in place, adjust the "0" angle by setting the mast straight on the centerline and tuning the **offset value** (see paragraph 3.2). The display should read « 0 » on the **ANGLE MAT** channel.
- Enter the **calibration value** (see paragraph 3.3), and check that the mast angle values that reads on the display matches the physical mast rotation. To do so, rotate the mast by  $10^\circ$  steps to align with marks made on the deck, up to  $40^\circ$ .
- When rotating the mast on port side (anticlockwise) the value should be -xx.

## 7.2 MAST ROTATION SENSOR MOUNTED WITH THE RUDDER ARM

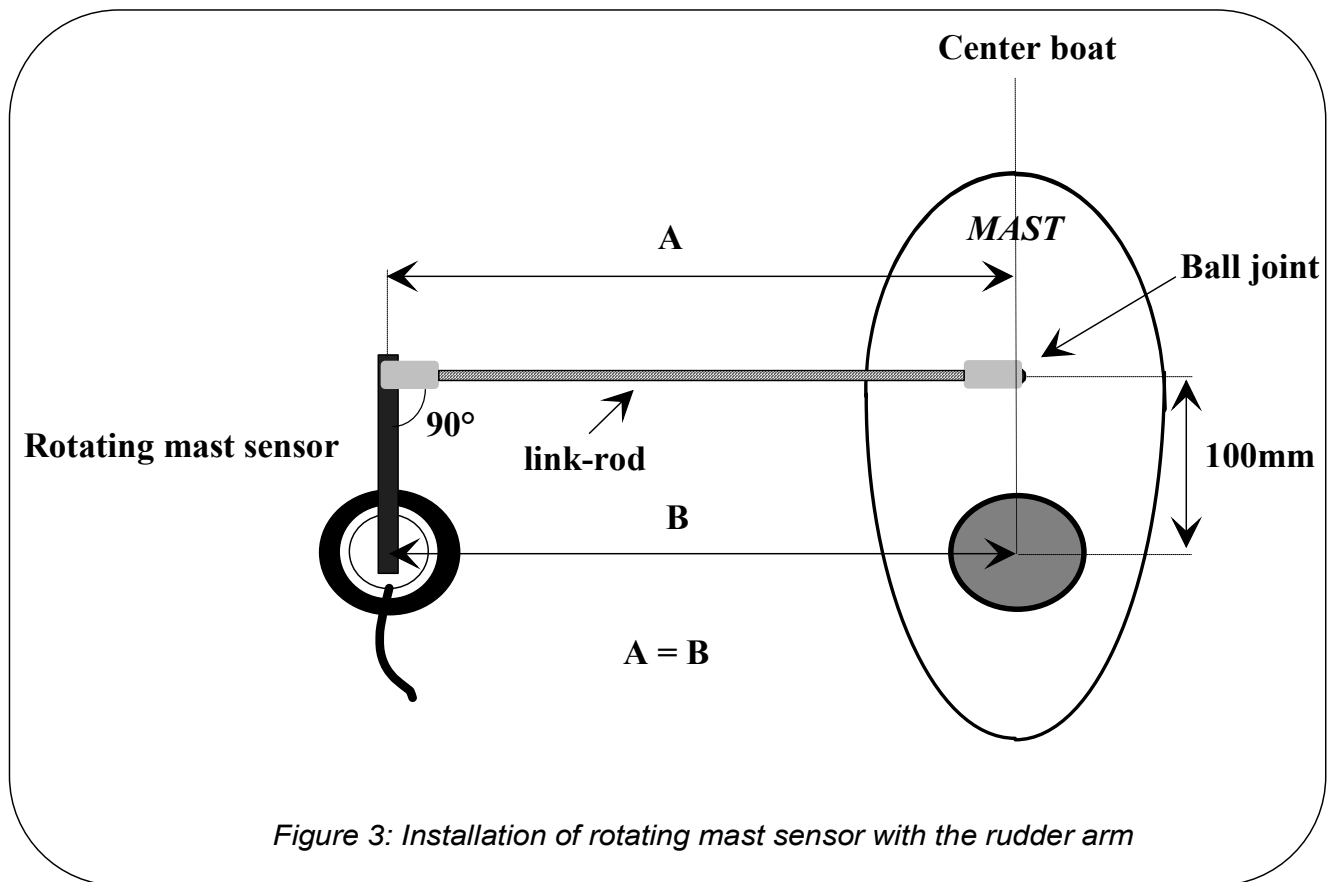

### 7.2.1 Mounting position

- When positioning the mast rotation sensor, make sure it shows the cable going to the aft of the boat. The sensor has a dead sector of  $\pm 10^\circ$  around the  $180^\circ$
- Maximum **A** distance is 360mm
- The 100mm distance between centre of rotation on the mast and the connection point for the link-rod must be 100mm.

### 7.2.2 Mounting the sensor



#### WARNING

Before completing the installation, you must check that the mast can freely rotate and that nothing can interfere with or damage the sensor, link-arm or cable

- Place the sensor as shown in Figure 3. Securely fasten with four screws ( $\varnothing$  4mm). Measure **A**.
- Fasten the link-rod to the mast centerline at 100mm from the center of rotation of the mast.
- Cut the screw thread to **A** – 22mm
- Set the end fittings at mid-distance and fit the screw thread on both sides, mast and sensor.
- Fine tune the end fitting with the screw thread until the rudder arm is perfectly parallel to the mast centerline ( $A=B$ )



- Lock the end fittings with the nuts.
- Adjust the “0” angle by setting the mast straight on the centerline and tuning the **offset value** (see paragraph 3.2). The display should read « 0 » on the **ANGLE MAT** channel.
- Enter the **calibration value** (see paragraph 3.3), and check that the mast angle values that read on the display matches physical mast rotation. To do so, rotate the mast by 10° steps to align with marks made on the deck, up to 40°.
- When rotating the mast on port side (anticlockwise) the value should be -xx.

## 8 CONNECTING TO THE *TOPLINE BUS*

Connecting the mast rotation sensor’s interface box to the connection box is described in Figure 4 below:

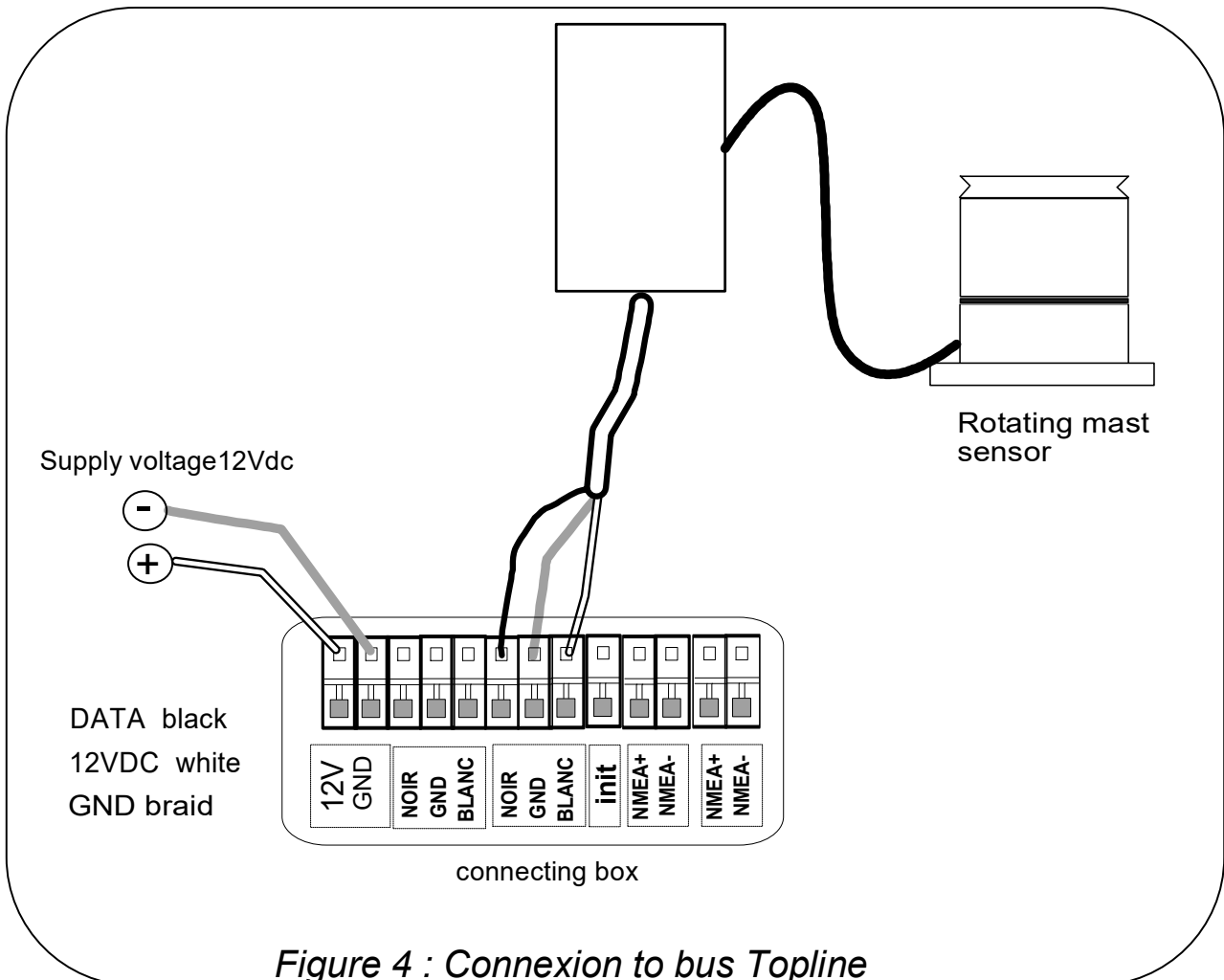

If you have to cut the bus cable, we recommend that the wires are tined connecting.



