

# BARO HR 100

Product reference : 90-60-358



## USER GUIDE and INSTALLATION GUIDE

Zi de Kerandré – Rue Gutemberg – 56700 – HENNEBONT – FRANCE

[www.nke-marine-electronics.com](http://www.nke-marine-electronics.com)

**nke**

**MARINE ELECTRONICS**



+33 297 365 685

## TABLE OF CONTENTS

<b>1</b>	<b>PRESENTATION .....</b>	<b>3</b>
<b>2</b>	<b>LIST OF CHANNELS DISPLAYED.....</b>	<b>4</b>
<b>3</b>	<b>SENSOR CALIBRATION.....</b>	<b>4</b>
3.3	OFFSET SETTING.....	4
<b>4</b>	<b>ALARMS SETTING.....</b>	<b>5</b>
4.1	PROCEDURE FOR ALARM SETTING ON VARIATION .....	5
4.2	PROCEDURE FOR ABSOLUTE ALARM SETTING (UPPER AND LOWER THRESHOLDS) .....	5
<b>5</b>	<b>FILTERING OF THE CHANNELS.....</b>	<b>6</b>
<b>6</b>	<b>NMEA 0183 OUTPUT .....</b>	<b>6</b>
<b>7</b>	<b>VISUALISING ATMOSPHERIC PRESSURE ON A PC.....</b>	<b>7</b>
<b>8</b>	<b>METER FOR ENGINE HOURS.....</b>	<b>8</b>
<b>9</b>	<b>EXTERNAL ALARM OUTPUT.....</b>	<b>8</b>
<b>10</b>	<b>TECHNICAL SPECIFICATIONS.....</b>	<b>8</b>
<b>11</b>	<b>DIAGNOSTIC OF 1<sup>ST</sup> LEVEL TROUBLESHOOTING .....</b>	<b>9</b>
<b>12</b>	<b>INSTALLATION .....</b>	<b>9</b>
12.1	LIST OF ACCESSORIES .....	9
12.2	INSTALLATION OF THE BARO HR 100.....	9
12.3	CONNECTION TO THE <i>TOPLINE BUS</i> .....	10

## 1 PRESENTATION

---

The *nke Baro HR 100* sensor is a measuring instrument that provides instant atmospheric pressure as well as the pressure variation over the previous 10 hours. It can be connected to the *nke TOPLINE bus* of your installation, or, thanks to its NMEA 0183 output, to any NMEA receiver that processes MMB, MTA and XDR frames. Compact and accurate ( $\pm 0.5$  mbar), this instrument will become an essential companion to prepare your weather forecast.

In addition, the *Baro HR 100* is fitted with a meter for engine hours, thus allowing to have an account of the hours of use of your engine.

The sensor is supplied with a 6 meter long *TOPLINE bus* cable.

### IMPORTANT

- Read this guide entirely before starting the installation.
- Any electrical connection on the *TOPLINE bus* must be carried out with the terminal box 90-60-417. Only use *TOPLINE bus* cable 20-61-001.
- Any intervention on the *TOPLINE bus* must be carried out with the installation power switched off.
- For channel settings, please refer to the user guide of your *TOPLINE* display.

## 2 LIST OF CHANNELS DISPLAYED

---

The **barometer**, connected to the **TOPLINE bus** of your installation, creates the following channels. It is accessible from the displays of the **TOPLINE** range.

Channel	Display	Unit
Barometer (mbar)	BARO <b>1015</b>	mbar
Barometer (100 <sup>th</sup> mbar)	ATM PRESS <b>1015.23</b>	mbar
Engine hour	ENG HOUR 23.5	Hour

## 3 SENSOR CALIBRATION

---

The **barometer** is adjusted at the factory. However, offset setting may be required to calibrate your sensor on the boat and obtain an absolute value that is optimal. Follow the calibration procedure below, while visualising the settings on a display : please refer to the user guide of your display.

### 3.3 OFFSET SETTING

#### 3.3.1 Principle

Air pressure in any given location can be taken as the weight of the air column that is above it, a variation of 1 meter in height in the sensor position causes a variation of approximately 0.1mbar on the measurement.

After installation, it may be necessary to adjust the **OFFSET** of the **barometer** so that the atmospheric pressure displayed is coherent with regard to the local pressure corrected at sea level. In order to do this, the **nke Baro HR 100** sensor has a double offset setting :

#### 3.3.2 Procedure for fine setting of the offset coefficient (by default the offset value is 0) :

This fine setting will enable a pressure correction of -9.99 mbar to +9.99 mbar.

1. Select the sub-channel **offset calib** of the **Atm Press** channel.
2. Enter the new **offset** coefficient and confirm by pressing **enter**. The new setting will be saved to the memory and will apply to the 2 Topline channels (Baro & Atm Press).

#### 3.3.3 Procedure for coarse setting of the offset coefficient (by default the offset value is 0) :

This coarse setting will enable a pressure correction of -999 mbar to +999 mbar.

1. Select the sub-channel **offset calib** of the **Baro** channel.
2. Enter the new **offset** coefficient and confirm by pressing **enter**. The new setting will be saved to the memory and will apply to the 2 Topline channels (Baro & Atm Press).

Please refer to the user guide of your display to perform the setting.

## 4 ALARMS SETTING

---

The setting of an alarm enables you to monitor the changes in atmospheric pressure in real time. With the **Baro HR 100**, you will be warned as soon as the changes in pressure or absolute pressure exceed the preset thresholds. When the preset alarm thresholds are exceeded, a warning message is displayed and an audible alarm is activated.

### 4.1 PROCEDURE FOR ALARM SETTING ON VARIATION

1. Display the **Atm Press** channel.
2. Select the sub-channel **Alarm Variation** and enter the chosen threshold value.

You can take into account the standard variations below to set your alarm :

- $Variation > 2.5\text{mbar/hr}$   $\Rightarrow$  *Transitional high pressure, unstable*
- $0.5\text{mbar/hr} < Variation < 2.5\text{mbar/hr}$   $\Rightarrow$  *Long-term high pressure, stable good weather*
- $-0.5\text{mbar/hr} < Variation < 0.5\text{mbar/hr}$   $\Rightarrow$  *Stable weather conditions*
- $-2.5\text{mbar/hr} < Variation < -0.5\text{mbar/hr}$   $\Rightarrow$  *Long-term low pressure, rain, stable*
- $Variation < -2.5\text{mbar/hr}$   $\Rightarrow$  *Transitional low pressure, storms, unstable*

To cancel the alarm, enter the value **0** in the **Alarm Variation** sub-channel.

Pressure variation is only available after one hour of use. After this first hour, the **Baro HR 100** constantly calculates the pressure variation over 1 hour.

### 4.2 PROCEDURE FOR ABSOLUTE ALARM SETTING (UPPER AND LOWER THRESHOLDS)

1. Display the channel **Atm Press**.
2. Select the sub-channel **Lower Alarm** and enter the chosen value for the lower threshold.
3. Select the sub-channel **Upper Alarm** and enter the chosen value for the upper threshold.

To cancel the alarm, enter the value **0** in the **Lower Alarm** and **Upper Alarm** sub-channels.

Thus, setting an alarm on the **Baro HR 100** will allow you to monitor the changes in weather conditions effectively.

To activate the alarms, please refer to the user guide of your display.

## 5 FILTERING OF THE CHANNELS

---

The level of **filtering** of a channel determines the frequency of update of the data displayed. For example, in rough sea when the ship moves significantly, it is useful to increase the filtering of the barometer to stabilise the value displayed.

**Filtering** is adjustable between **1** and **32**, and the default value is **8**. The lower this value, the higher the frequency of update.

Please refer to the user guide of your display to adjust the filter setting.

## 6 NMEA 0183 OUTPUT

---

Every second, the **BARO HR 100** transmits the atmospheric pressure and air temperature to its NMEA output (yellow wire). Note that it is possible to independently use the NMEA 0183 output and the **Topline** bus link. However, the data transmitted over the NMEA link take into account the existing settings in the **Topline** sub-channels (Offset and filtering).

The atmospheric pressure is transmitted in the XDR and MMB frames while the air temperature is transmitted in the XDR and MTA frames.

Example of NMEA transmission :

\$IIXDR,P,1.02481,B,Barometer\*0D

\$IIXDR,C,19.52,C,TempAir\*3D

\$IIMTA,19.52,C\*1E

\$IIMMB,30.3446,I,1.02481,B\*65

Connection parameters : 4,800 bauds - 8 bits - 1 stop bit - no parity

## 7 VISUALISING ATMOSPHERIC PRESSURE ON A PC

A PC software available from our website [www.nke.fr](http://www.nke.fr) will allow you to display a graph that shows the evolution of temperature and atmospheric pressure.

In the centre of the screen, an indication of the change in pressure over the last hour and last two hours elapsed will help you to gauge the weather tendency.

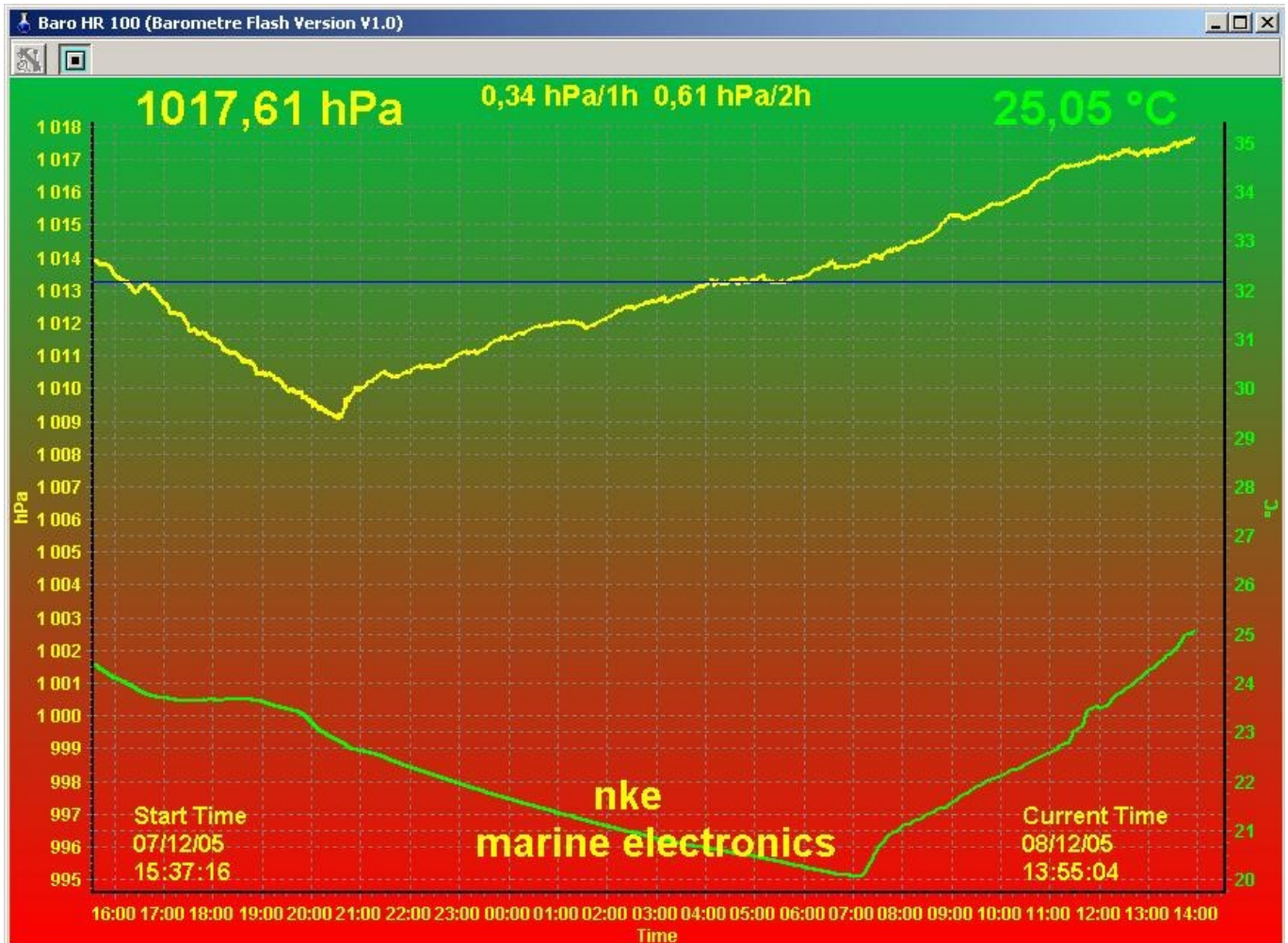

It is possible to save the measurements to a text file according to 4 different recording rates. This recording rate as well as the selection of the COM port used can be set in the *Settings* window (see opposite).

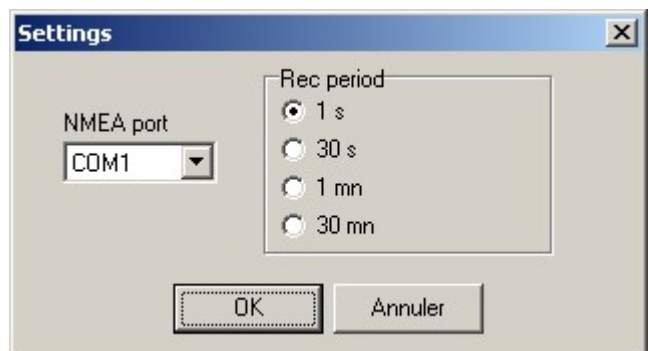



## 8 METER FOR ENGINE HOURS

---

The **Baro HR 100** comes standard with a control entry for the engine hours meter (red wire). Connected to the engine's contactor (+12V after contact), this input enables **Baro HR 100** to measure the cumulated time of use of the engine in tenths of an hour.

To deactivate the meter, the red wire must be connected to the earth or not connected.

The **Offset** sub-channel can be used to reset the meter to a specific value.

An alarm for critical duration overshoot is also available ; to activate this alarm, you must enter a non-zero value in the **Upper Alarm** sub-channel.

## 9 EXTERNAL ALARM OUTPUT

---

The External Alarm output (green wire) is of the open collector type and is there to enable a 50mA load at 12VDC to be sent to the earth. This output will be activated when an alarm from the **Baro HR 100** (Pressure, Engine Hour) or a Topline alarm is detected (MOB alarm or sensor alarm).

## 10 TECHNICAL SPECIFICATIONS

---

### General :

- Power supply : 10 to 16VDC
- Consumption : 25mA
- Tightness : IP54
- Weight : 270 g (with 5 meters of cable)
- Operating temperature : -10°C to +50°C
- Storage temperature : -20°C to +60°C

### Pressure :

- Measurement range : 800 to 1100 mbar
- Resolution : 0.01 mbar
- Relative accuracy :  $\pm 0.5$  mbar at 25°C from 800 to 1100 mbar
- Absolute accuracy :  $\pm 1.5$  mbar at 25°C from 800 to 1100 mbar

### Temperature :

- Measurement range : -10°C to +50°C
- Resolution : 0.01 °C
- Accuracy :  $\pm 0.8$  °C at 20°C



## 11 DIAGNOSTIC OF 1<sup>ST</sup> LEVEL TROUBLESHOOTING

Before contacting technical support, please check the troubleshooting table below.

Problem	Possible causes and solutions
The <b>Topline</b> installation does not detect the Baro HR 100	The bus cable is not or is badly connected to the terminal box : check the plugging and the connection inside the terminal box. Check the state of the cables : they must not show any sign of wear or cut.
The <b>Topline</b> ATM PRESS and BARO channels display the message FAULT.	Cut the power supply of the sensor for a few seconds. If the problem persists after switching the power back on, contact technical support.

If you do not manage to solve the problem, please contact your distributor.

## 12 INSTALLATION

Before starting the installation, take the time to choose the most appropriate place for the sensor. Indeed, although it is temperature compensated, the **Baro HR 100 TOPLINE** must not be exposed to a heat source (solar radiation, cooking plate, etc...).

### 12.1 LIST OF ACCESSORIES

- TOPLINE Terminal box : 90-60-121
- TOPLINE bus cable : 20-61-001

### 12.2 INSTALLATION OF THE BARO HR 100

- Fix the housing using  $\varnothing 4$  screws

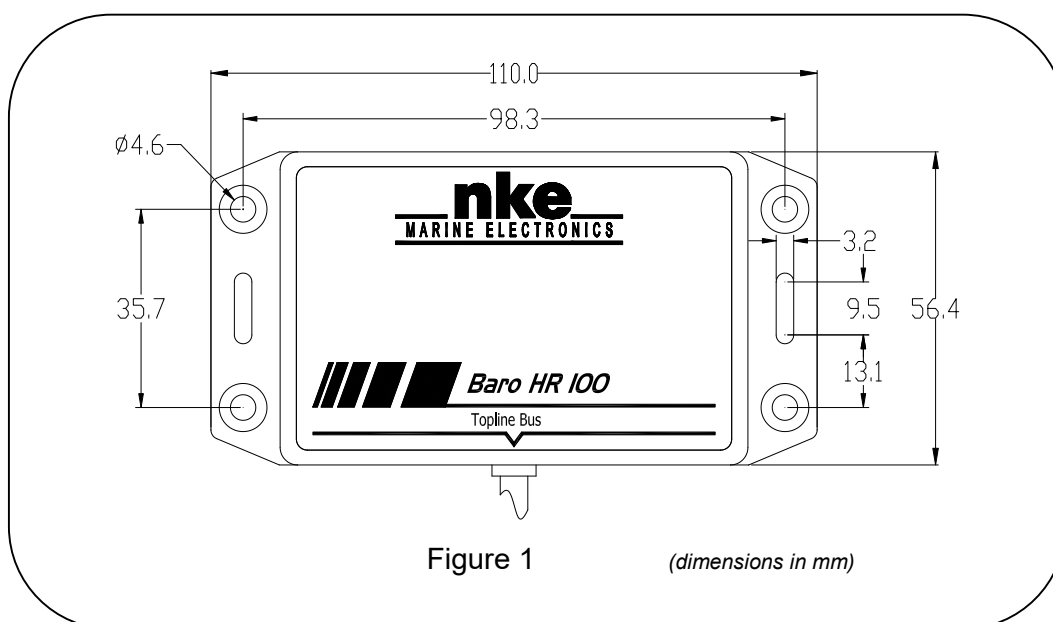

### 12.3 CONNECTION TO THE *TOPLINE BUS*

Connect the **Baro HR 100** bus cable inside the terminal box according to the drawing below :

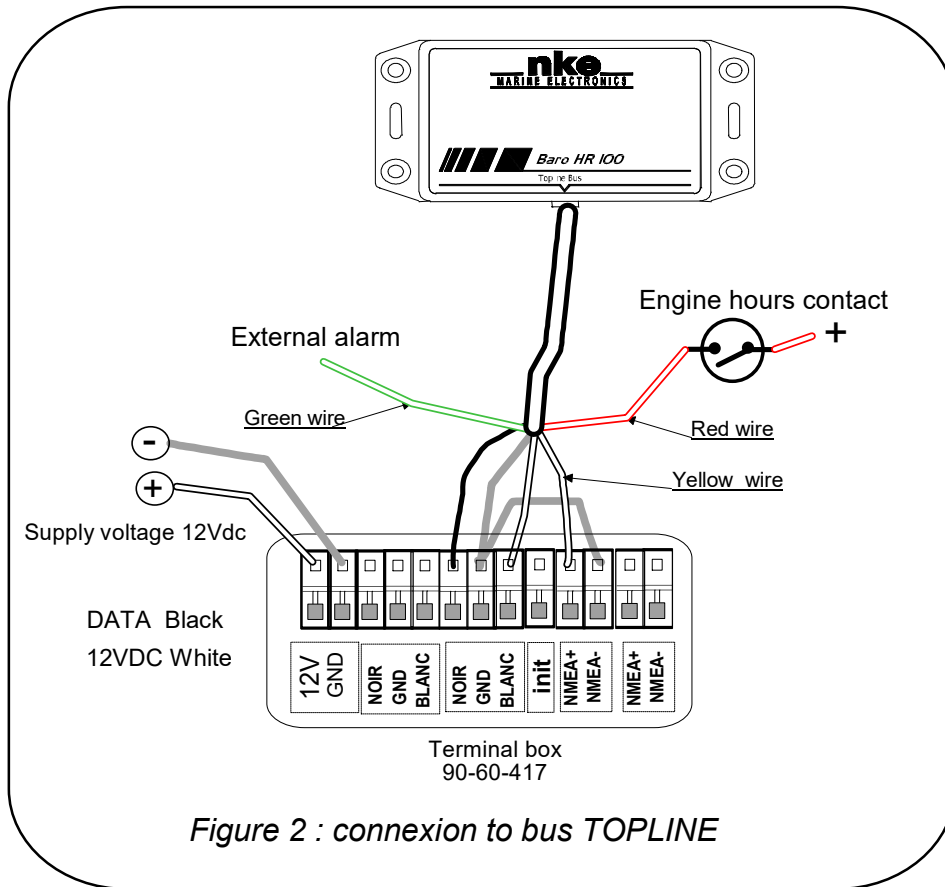

If you reduce the length of the bus cable, strip and galvanise the wires before connecting them inside the terminal box.



